

AOYUE

850

SMD REWORK STATION

1. State defense product, protection of PCB from static and leak electricity.
2. The situation of manual operation of accessories are over heated could be avoided by the precision of the weld without touch the welding point.
3. The temperature control system could be adjusted in a wide range, as applied in different type of components to the application of different type of devices could be selected to avoid or reduce the solder.
4. The material is in some quality with international brand.
5. High quality and turn-off power switch. The unit will power off automatically when the power is off through the pipe for a short period time across the heating element's and handle's side.

Preparation Work

- Select the TP (temperature) with the size of 1.5mm or 2.0mm. The TP should be prepared in advance. If the TP is not prepared in advance, it will be prepared in advance.
- Select the TP (temperature) with the size of 1.5mm or 2.0mm. The TP should be prepared in advance. If the TP is not prepared in advance, it will be prepared in advance.

INSTRUCTION MANUAL

一、Specification

Power Consumption	110V-250W	220V-270W
Pump	Diaphragm Pump	
Capacity	24L/min(max)	
Measure the resistance value (The correct values are approximately)	(100V-120V)26-40Ω (220V-240V)70-100Ω	
Fuse	5A (100V-120V) 3.15A(220V-240V)	
Control Temperature	100°C-500°C	

* This product is ESD-Protected.

* Specifications and design subject to change without notice.

二、Function

1. Static defense prevent the fault of PCB from static and leak electricity.
2. The situation of moving accessories or accessories are over heated could be avoided by the method that to weld without touch the welding point.
3. The temperature and airflow could be adjusted in a wide vage, is applied to OFP and SOP type IC. According to the application different type of Nozzle could be selected to weld or remove the solder.
4. The Nozzle is in same quality with international brand.
5. After work and turn off the power switch. The unit will automatically blow cool air through the pipe for a short period time. ensure the heating Element' s and Handle' s Life.

Prepare work before operation

- * Select the FP pick-up wire, The size of it and IC should match, FP pick -up. Has a small wire (1.4mm) but it probably needs a big FP pick-up wire (30mm) Please choose the suitable FP pick-up wire according to the size of IC.
- * Select the suitable nozzle, which should be matched with IC in size.
- * Ploosen the screw on the Nozzle.
- * Attach the Nozzle as shown in the drawing.
- * Reinforce the screw, but do not too tightly.

三、Precautions

1. Thermal Protector

If the thermal protector trips, reduce the temperature setting or increase the air flow.

2. For safety, power is automatically shut off should the unit exceed a certain temperature. Once the temperature has dropped to a safety level, power is automatically turned on.

Turn off the switch and cool the iron. After that, to continue operation, reduce the temperature setting or increase the air flow. Should the Thermal Protector be tripped and you do not wish to continue the operation or if you leave that place, be sure to turn the Power Switch off.

3. Caution-- high Temperature Operation

Do not use the unit near ignitable gases, paper, or other inflammable materials. Both the nozzle and the heated air are extremely hot and can cause painful burns. Never touch the heater pipe or allow the heated air to blow against your skin. Initially, the iron may emit white smoke, but this will soon disappear.

4. After use, be sure to cool the unit.

After turning off the power switch, the unit will automatically blow cool air through the pipe for a short period of time. Do not disconnect the plug during this cooling process.

5. Never drop or sharply jolt the unit.

The pipe contains quartz glass which can break if the unit is dropped or jolted sharply.

6. Do not disassemble the pump.

7. Disconnect the plug when you don't use the unit for a long time.

When the power cord is connected into the power supply, the unit has a little flow of electricity, even the Power Switch is in off position. So when you don't use the unit for a long time, disconnect the plug.

Attaching the Nozzle.

1. Loosen the screw on the Nozzle.

2. Attach the Nozzle as shown in the drawing.

Do not force the Nozzle or pull on the edge of the Nozzled by pliers. Also, do not retighten the screw too tightly.

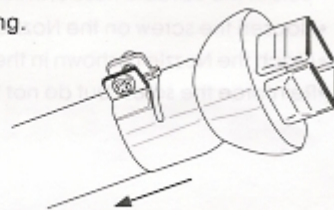

Operating Instructions

QFP Desoldering

1. Plug the power cord into the power supply.

After connection, the automatic blowing function will start sending air through the pipe, but the Heating Element remains cool.

2. Turn the power switch on.

The Power Switch may be turned on at any time while the automatic blowing function is operating. Once the Power Switch is turned on, the Heating Element will begin to warm up.

3. Adjust the Air Flow and Temperature Control Knobs.

After adjusting the Air Flow and Temperature Control Knob, wait for the temperature to stabilize for a short period of time. Refer to the temperature distribution chart. For your reference, we recommend you to adjust the temperature around 300 to 350°C. As for Air Flow in case of single nozzle, set the knob 1~3, in another nozzle, set it from 4~6. When using a single nozzle, never set the Temperature Control Knob to higher than 6.

4. Place the FP Pick-up under the IC lead.

Slip the FP Pick-up Wire under the IC lead. If the width of the IC does not match the size of the FP Pick-up, adjust the width of the wire by supressing the wire.

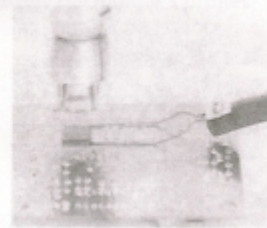

5. Melt the solder.

Hold the iron so that the Nozzle is located directly over, but not touching the IC, and allow the hot air to melt the solder. Be careful not to touch the leads of the IC with the nozzle.

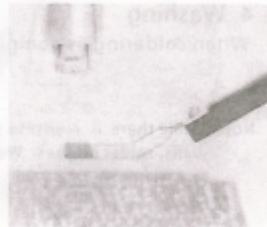

6. Remove the IC.

Once the solder has melted, remove the IC by lifting the FP Pick-up.

7. Turn the Power Switch off.

After the Power Switch is turned off, an automatic blowing function begins sending cool air through the pipe in order to cool both the heating element and the handle. So do not disconnect the plug during this cooling process. In case you don't use the unit for a long time, disconnect the plug.

8. Remove any remaining solder.

After removing the IC, remove remaining solder with a wick or desoldering tool.

Note: in case of SOP, PLCC, desolder it by using tweezers, etc.

QFP Soldering

1. Apply the solder paste.

Apply the proper quantity of solder paste and install the SMD on the PWB.

2. Preheat SMD.

Refer to the photo to preheat SMD. (Fig. I)

3. Soldering

Heat the lead frame evenly.
(Fig. II)



Fig. I

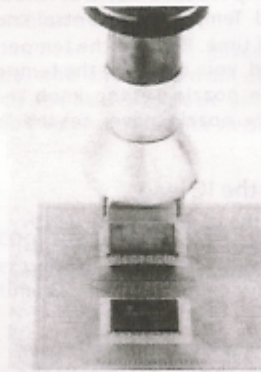

Fig. II

4. Washing

When soldering is completed, wash away the flux.

Note: While there is merits to solder by Hot air, it's also possible to cause the defects such as solder balls, solder bridges. We recommend you to examine the conditions of soldering sufficiently.

Replacing the Heating Element

1. Remove the screws, slide the tube.

Remove the 3 screws (Fig. I -1,2,3) which secure the handle and slide the cord tube.

2. Open the Handle.

Disconnect the ground wire sleeve (Fig. II-1) and remove the pipe. In the pipe, the Quartz glass and heat insulation is installed. Do not drop or miss it.

3. Remove the Heating Element..

Disconnect the terminal (Fig. II-2) and remove the Heating Element.

4. Insert a new Heating Element

Handle it with care. Never rub the Heating Element wire. Insert a new Heating element and reconnect the terminal. Reconnect the ground wire after replacing the element. Assemble the Handle in the reverse order of disassembly. Insert the handle's projection into the hole in the pipe.

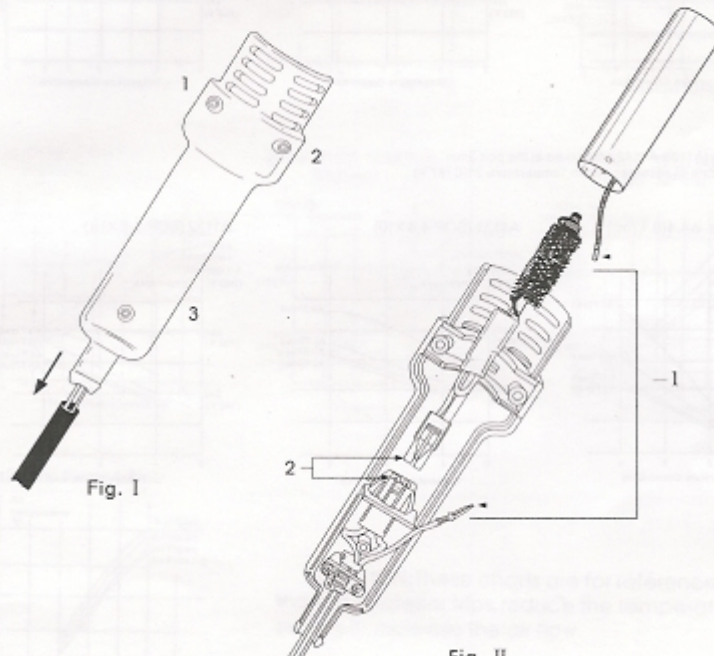

Optional nozzles

